

PIATTAFORMA AUTOCARRATA 40 mt

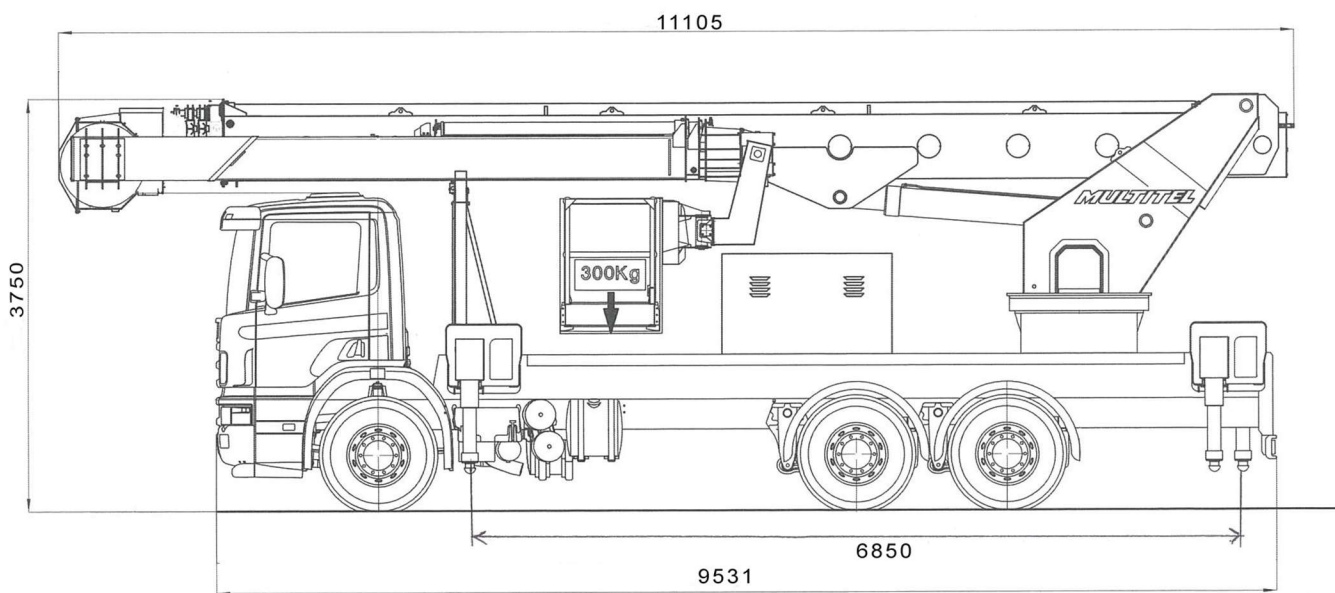

www.fratelliboscaro.it

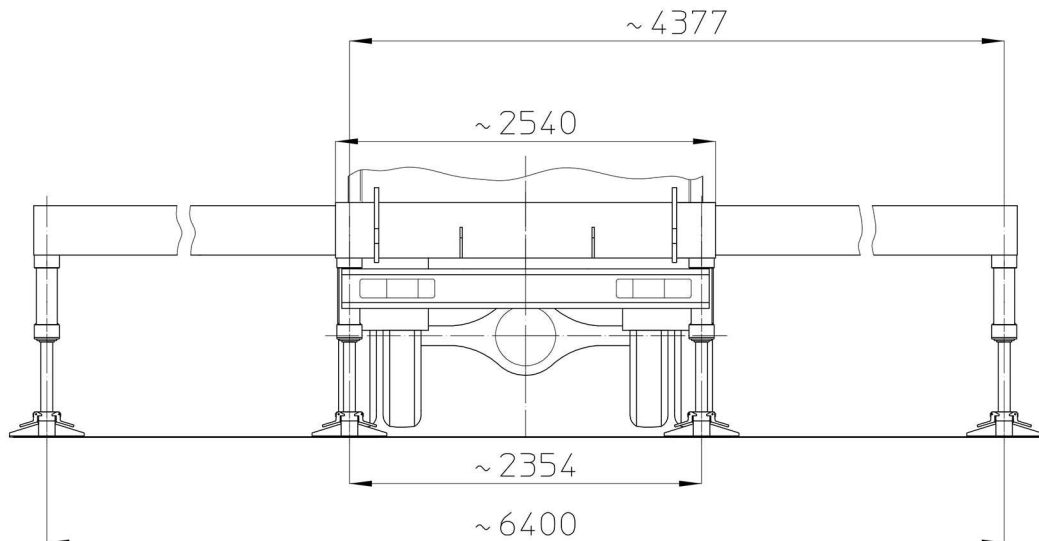
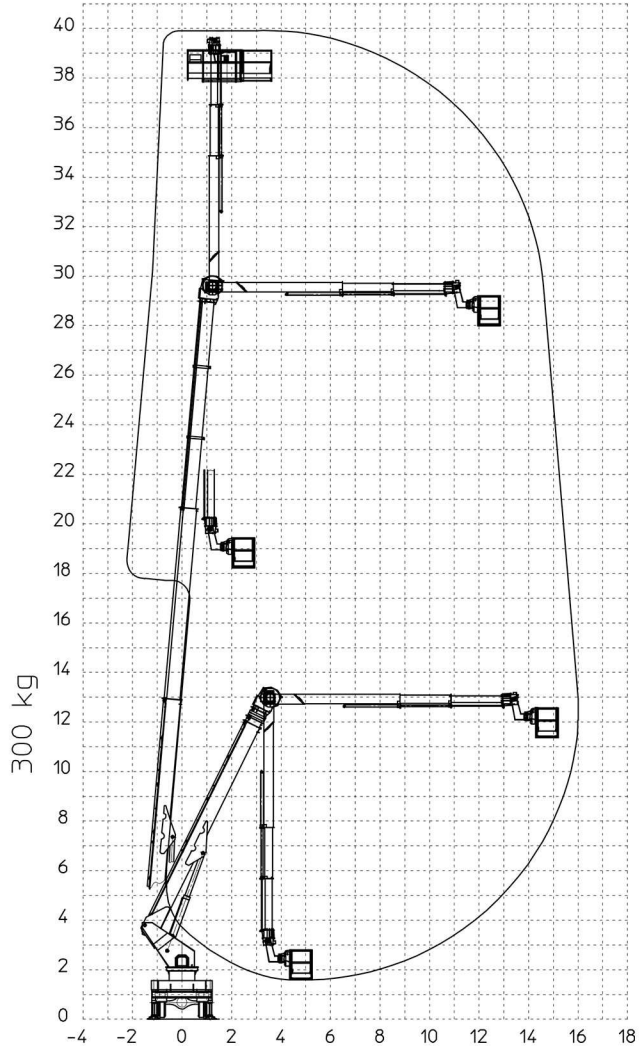
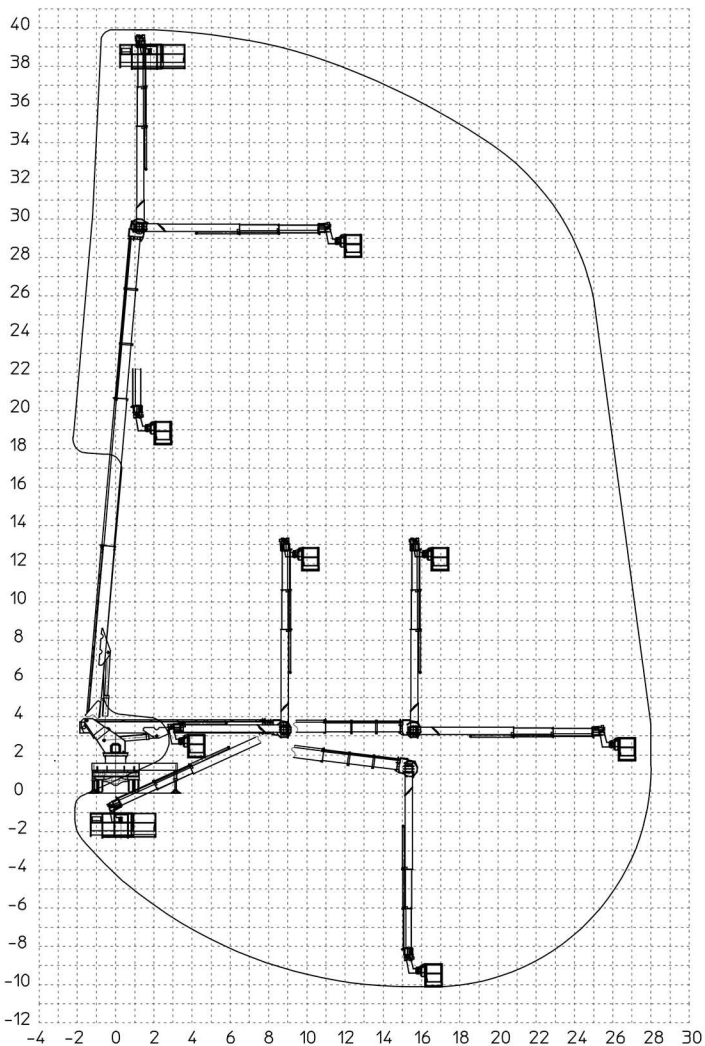

CARATTERISTICHE

Peso: 260 quintali
Peso scarico a terra stabilizzatori
anteriori 21500 da N
posteriori 23000 da N

F.lli Boscaro S.r.l

Via Libertà, 50 | 13856 VIGLIANO B.SE (BI)

Tel. 015512268 - fax 015512971

www.fratelliboscaro.it